

NACTA meeting (June 20th, 2019)



Use of Analogies to Enhance Student Engagement and Learning

Zhiyong Cheng, PhD
Food Science and Human Nutrition Department
The University of Florida



To explain it simply: how and how much?

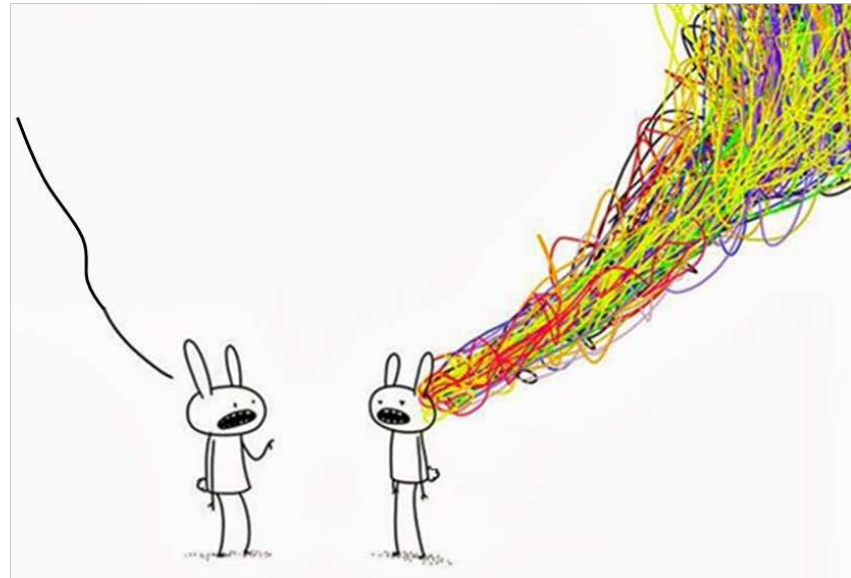
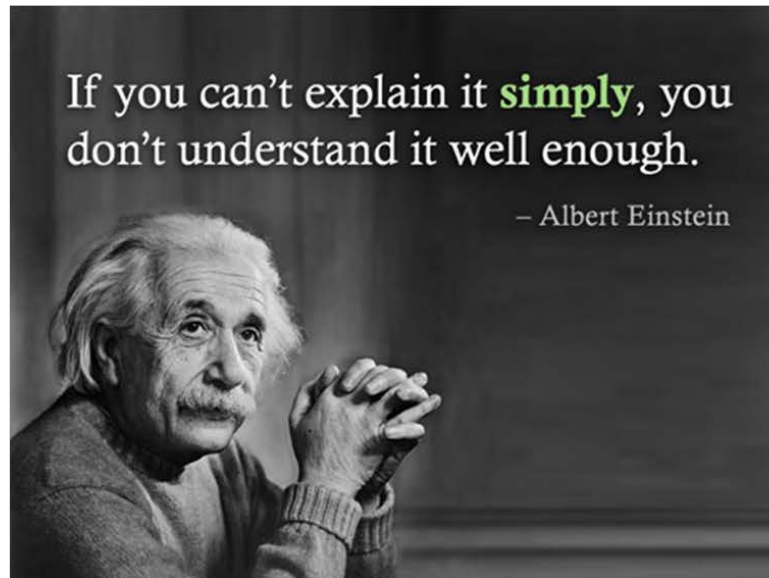

Explaining through visualization

How can one be happy?

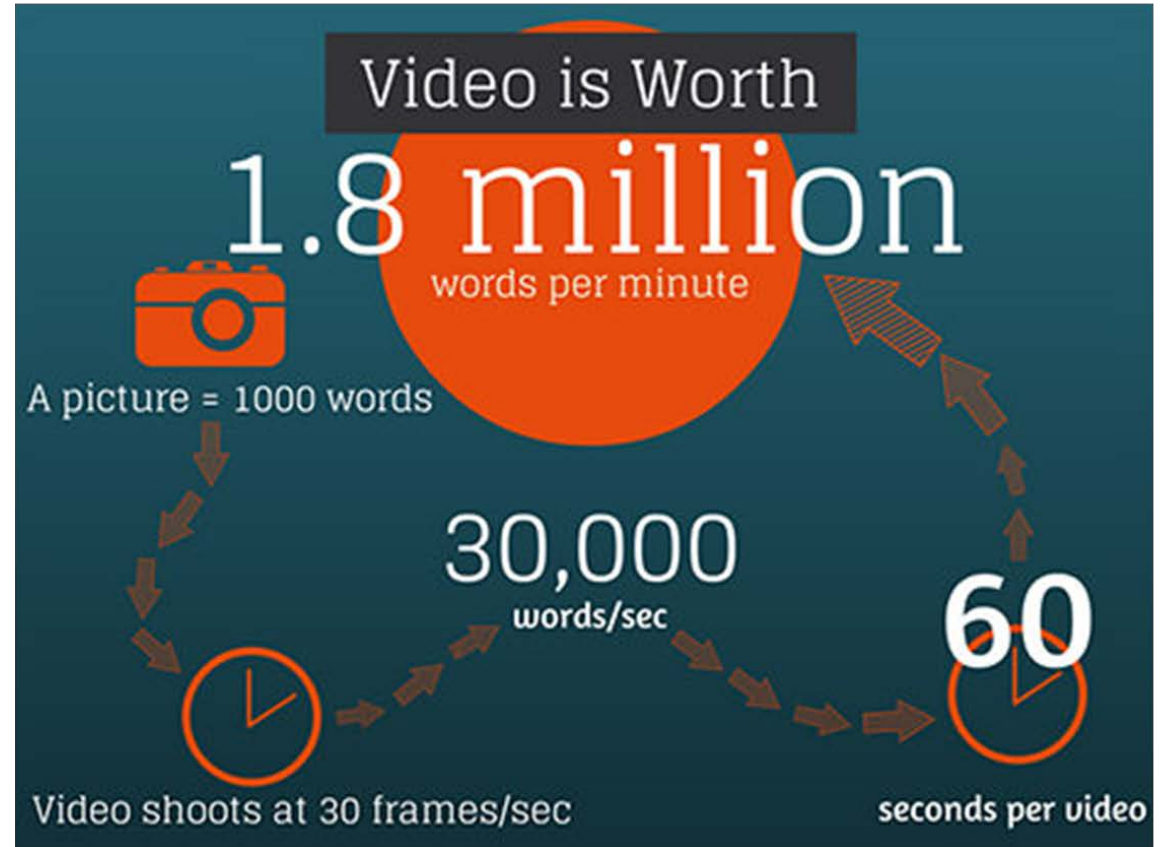

“The tangibility of the concept is strengthened by using everyday items that not only capture student interest, but also help them retain the information and, likely, apply it to new situations” (Seiler and Huggins, 2018)

Visualization via analogy

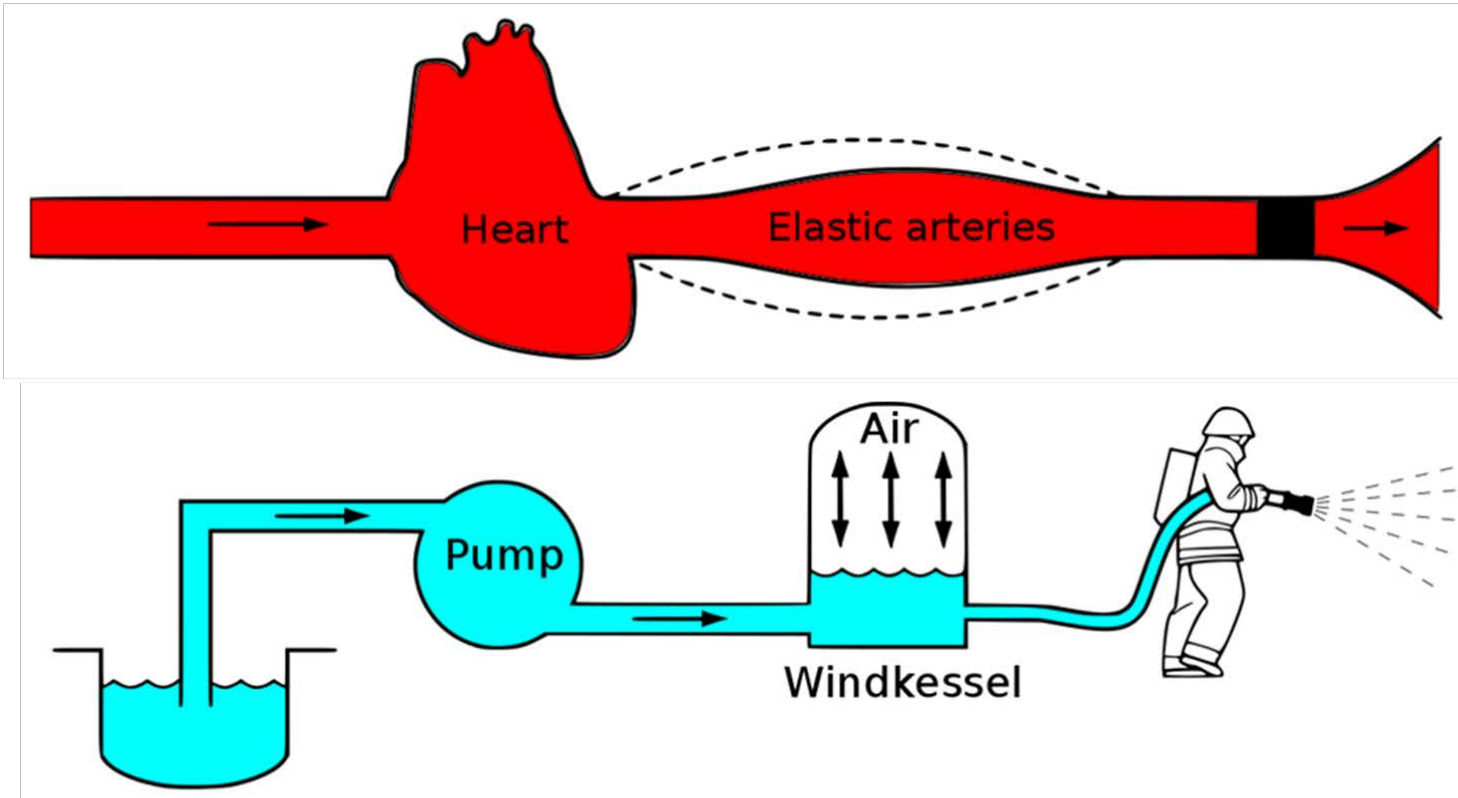

Windkessel effect: air chamber vs elastic reservoir

Hales S (1733)

What is analogy?

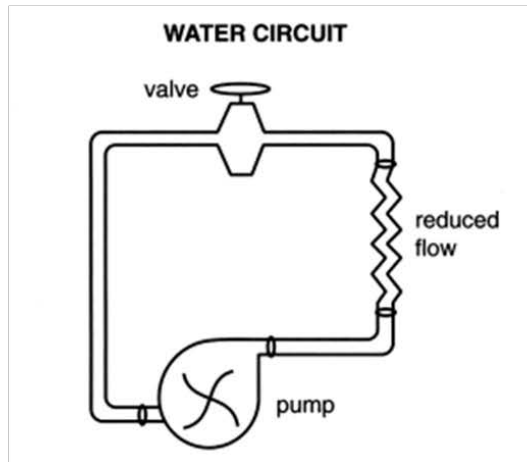
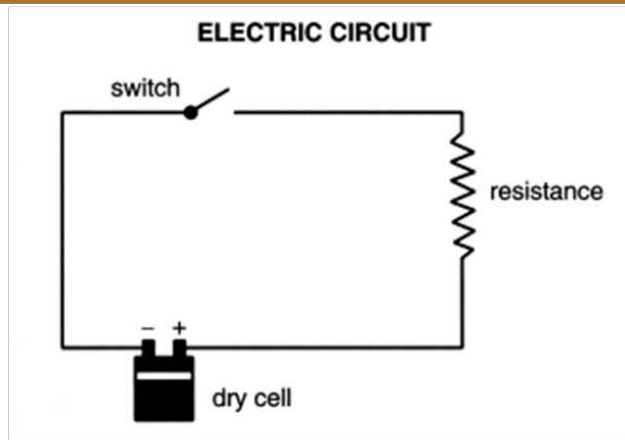

- Simply, analogies compare two concepts or ideas—one that is familiar and one that is less familiar.
- Specifically, an analogy is a mapping of knowledge from one domain (the base) onto another (the target). The objects that make up the base have specific attributes and are linked by a system of relations, which also holds in the target.
 - Electric circuit (invisible)
 - Water circuit (visible)
- The objects that make up the base have specific attributes and are linked by a system of relations, which also holds in the target.
- Base and target have common attributes and common relations -- similarity
- Base and target have common attributes but do not share relations -- superficial similarity
- Base and target do not have common attributes but do share relations -- analogy
 - The strength of an analogy depends on the interdomain consistency of the relations rather than the attributes.

The concept and constituent parts of an analogy

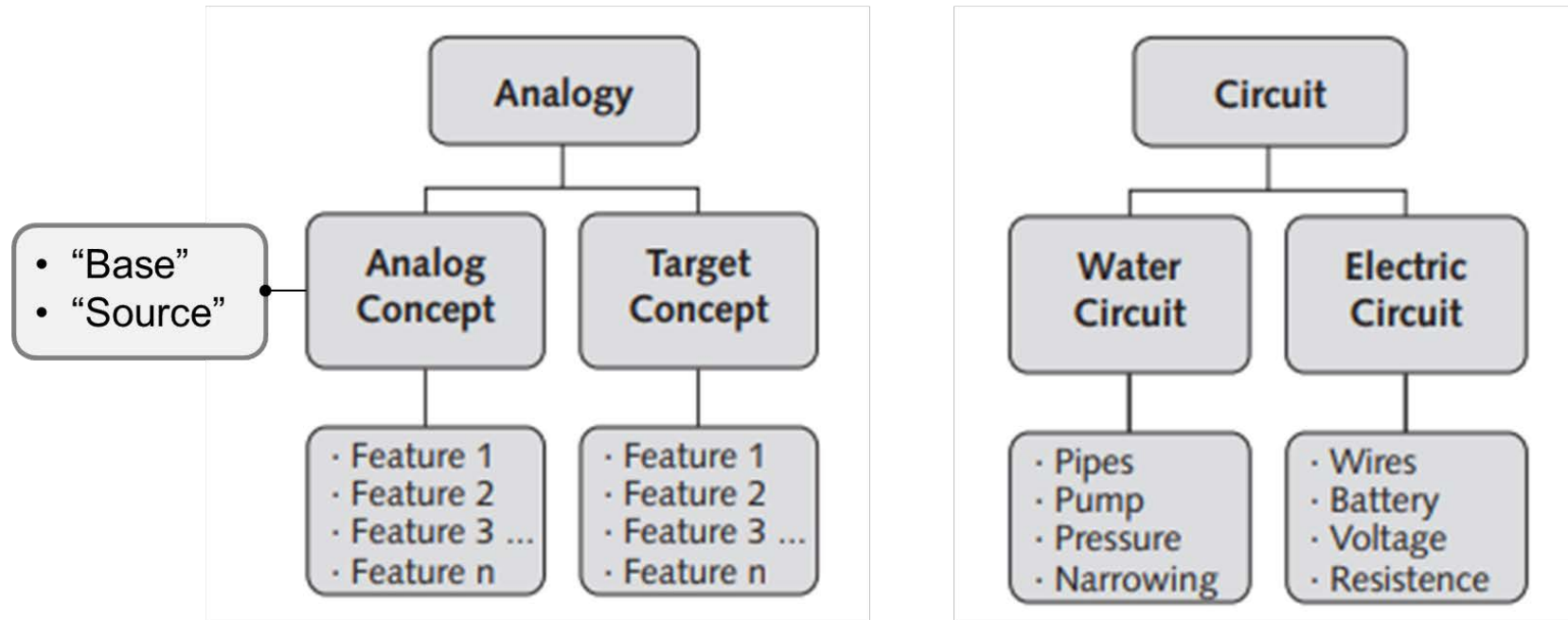

- The familiar concept is referred to as **the analog (or base, or source)**
- The concept less familiar or to be learned, is referred to as **the target**

Analogy, similarity, and identity

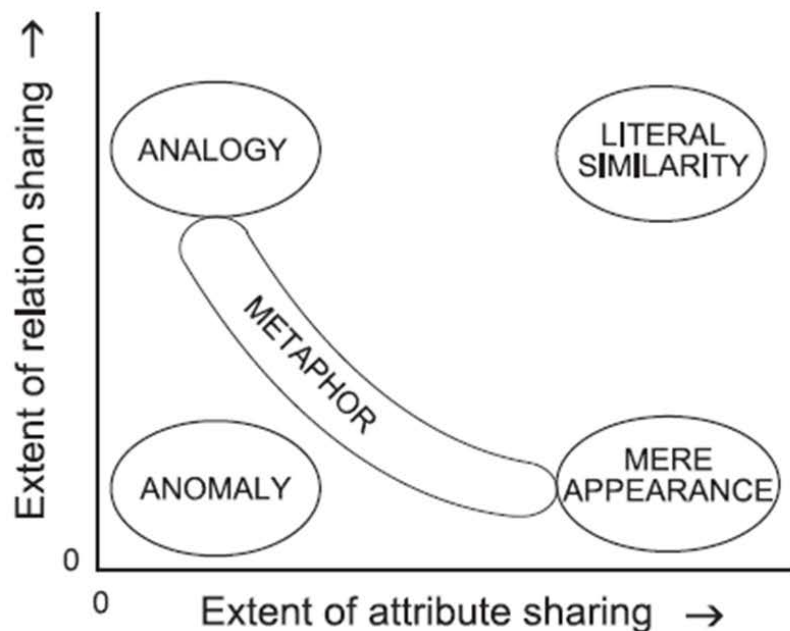

- The similarity space indicating the sharing of relations and attributes between the base and target domains.
- In an analogy, the relations are shared between the base and target, but the attributes are not.
- If the base and target share attributes but not relations, their similarity is superficial
- If they share both relations and attributes, they are literally similar (or perhaps even identical).

Mitochondrion to a Cell like the Engine to a Car

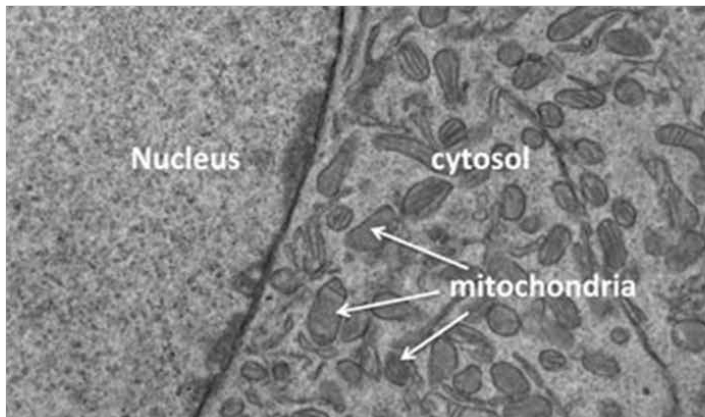

- Mitochondria in the cell
- Fuel
 - Carbohydrate
 - Fat
 - Protein



- Engine in a car
- Fuel (gas)

Mitochondria in nutrient and energy metabolism

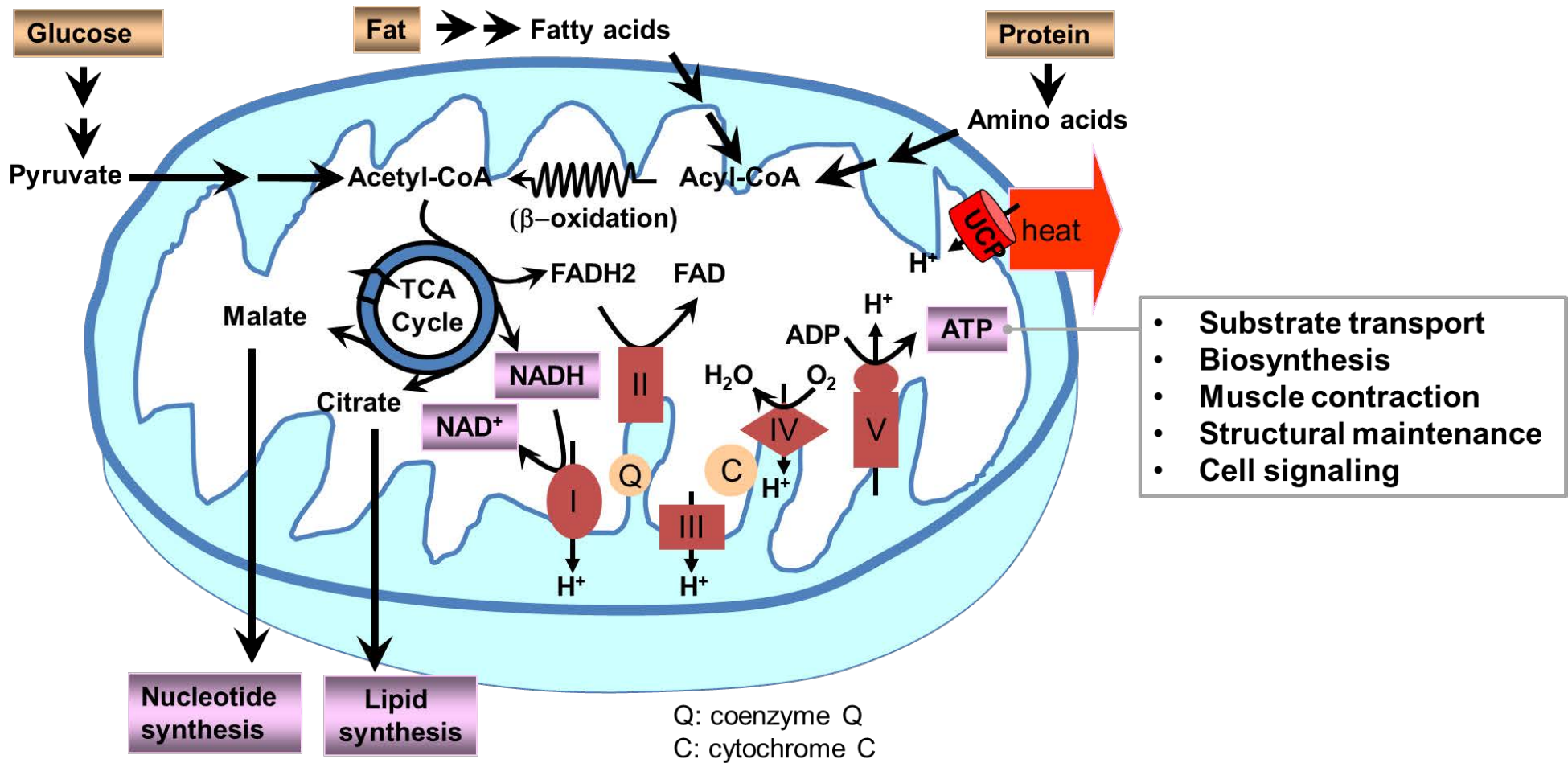

Analogy for mitochondrial metabolism

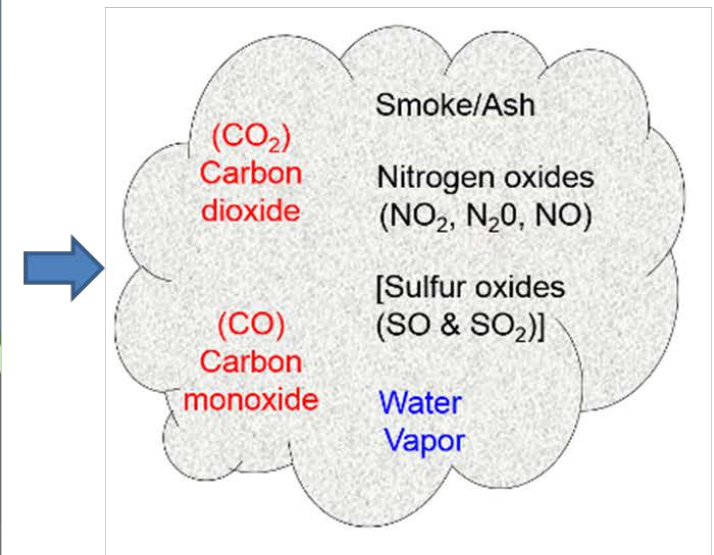
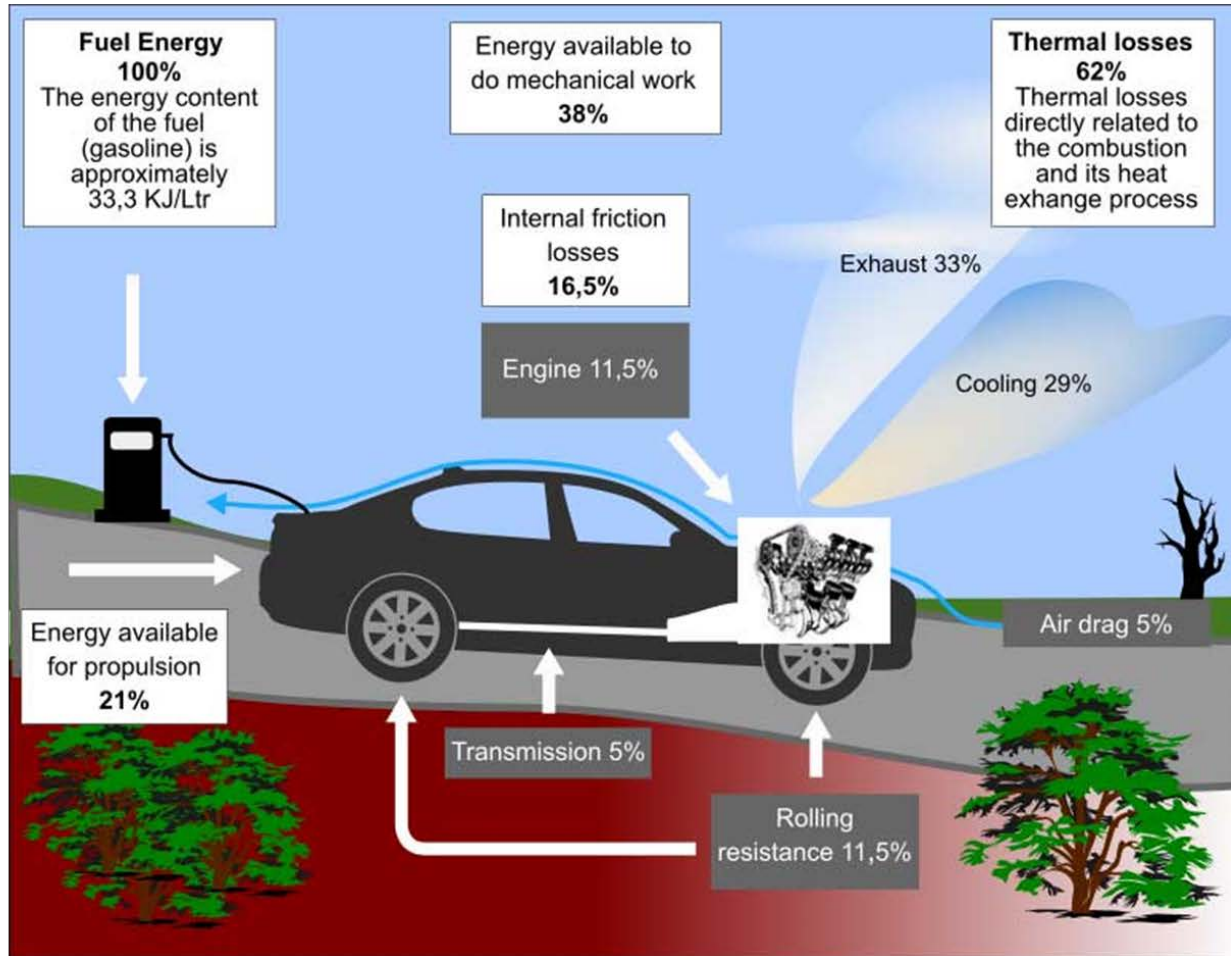

Byproducts of mitochondrial respiration

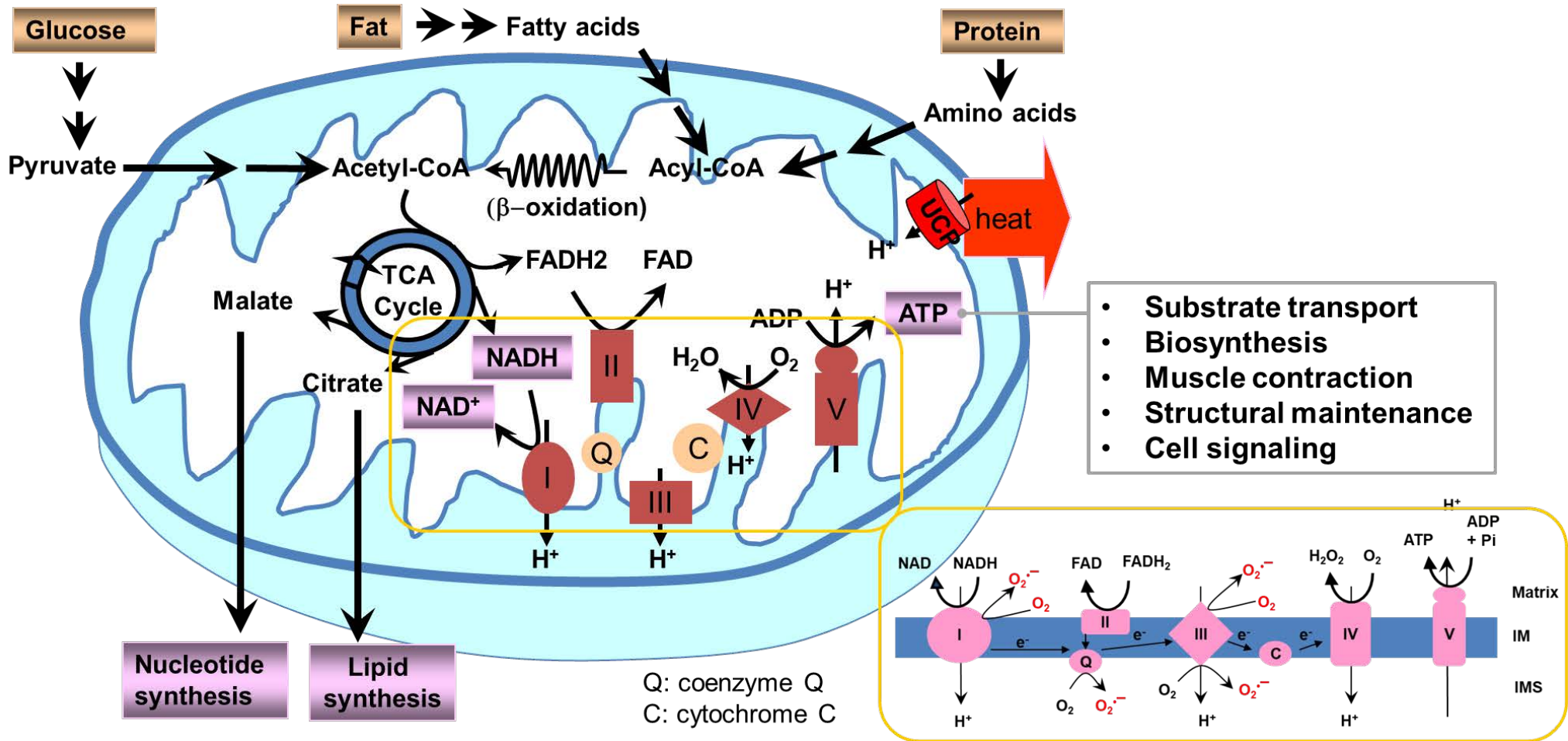

Insulin signaling in metabolism

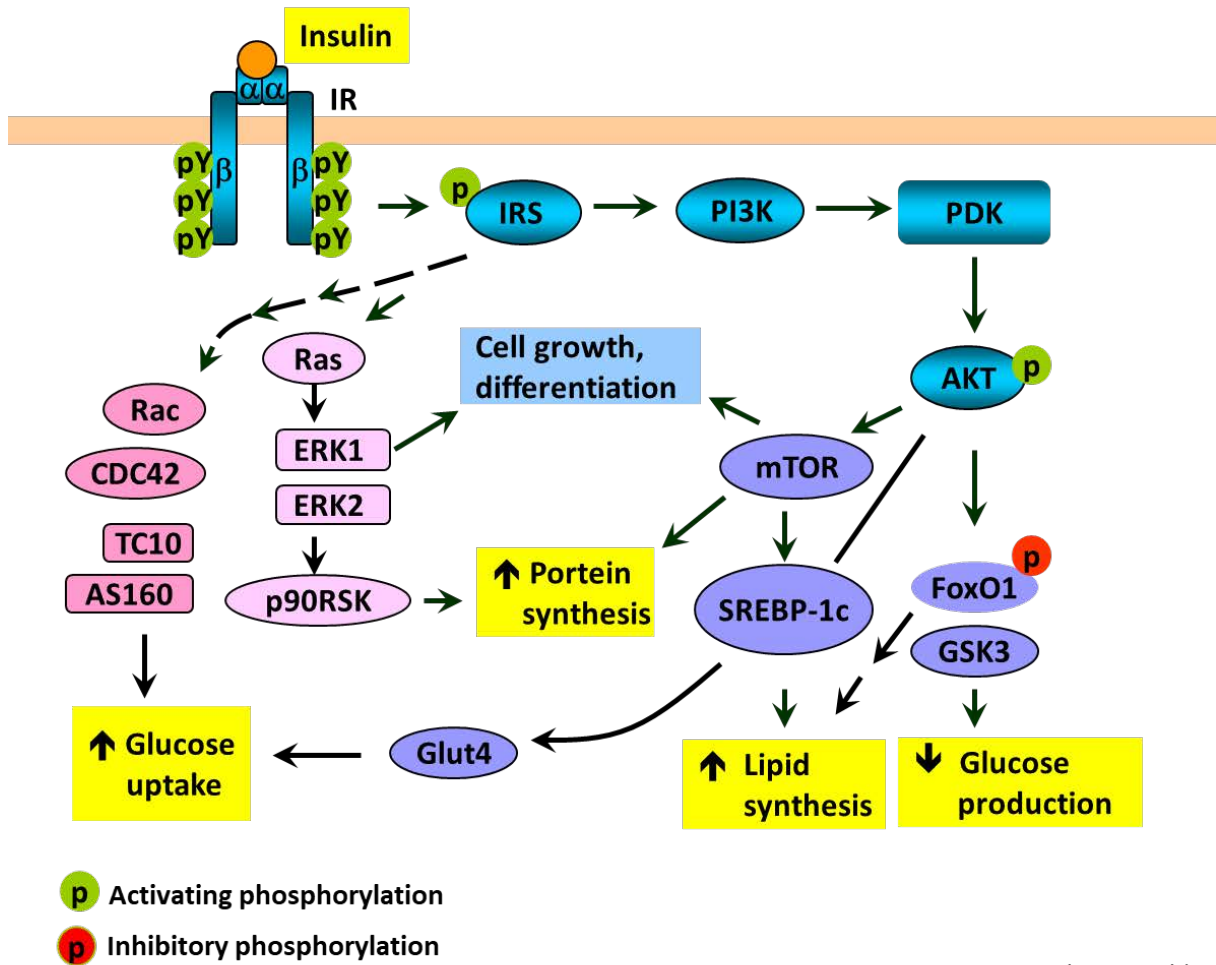

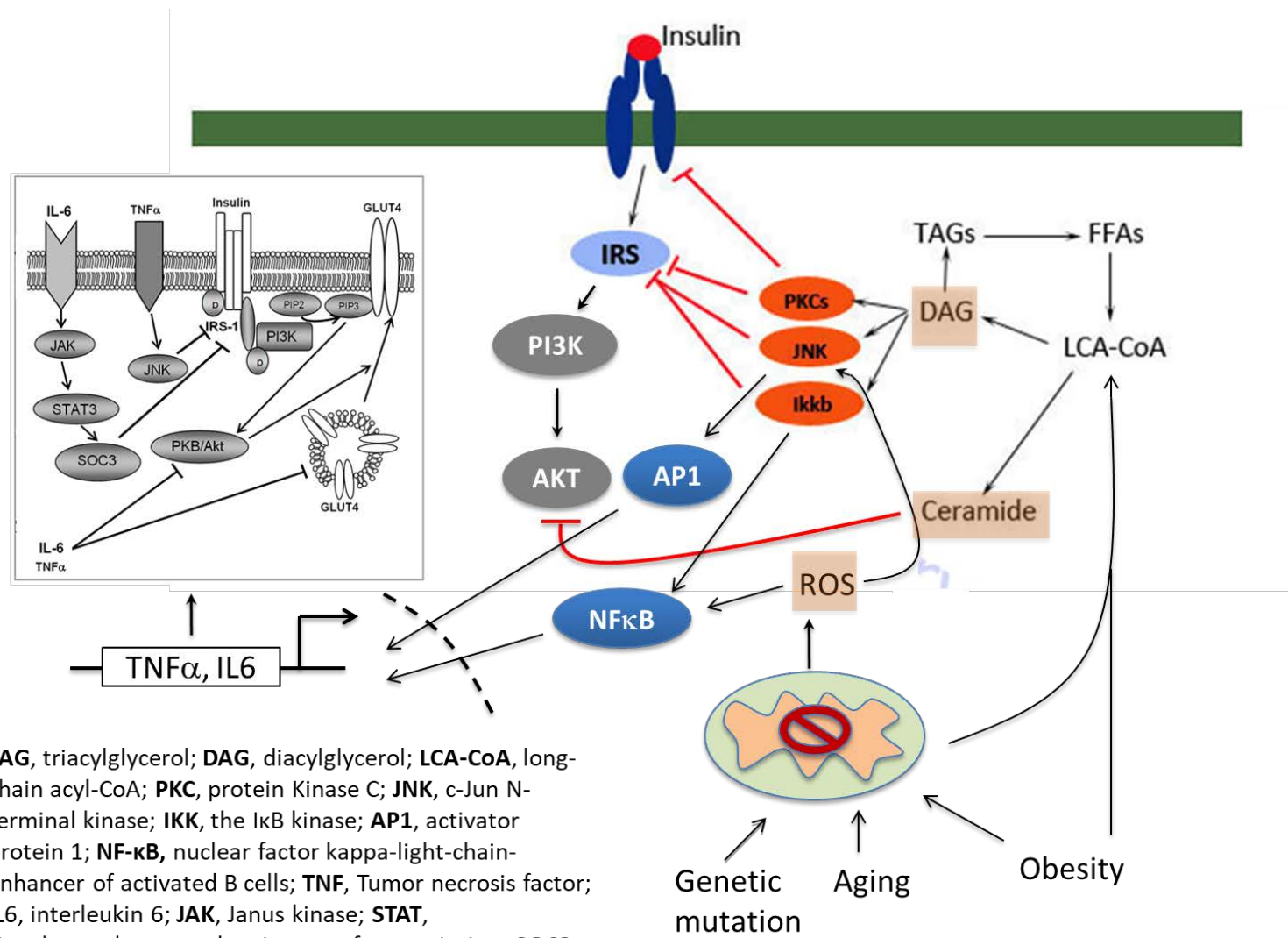

TAG, triacylglycerol; **DAG**, diacylglycerol; **LCA-CoA**, long-chain acyl-CoA; **PKC**, protein Kinase C; **JNK**, c-Jun N-terminal kinase; **IKK**, the I κ B kinase; **AP1**, activator protein 1; **NF- κ B**, nuclear factor kappa-light-chain-enhancer of activated B cells; **TNF**, Tumor necrosis factor; **IL6**, interleukin 6; **JAK**, Janus kinase; **STAT**, signal transducers and activators of transcription; **SOC3**, suppressor of cytokine signaling 3.

Mitochondrial dysfunction impairs insulin signaling



Poor-regulated factory

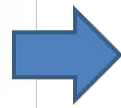

Industrial waste



Polluted river

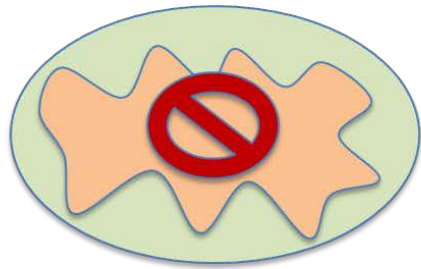

Poor-quality mitochondria

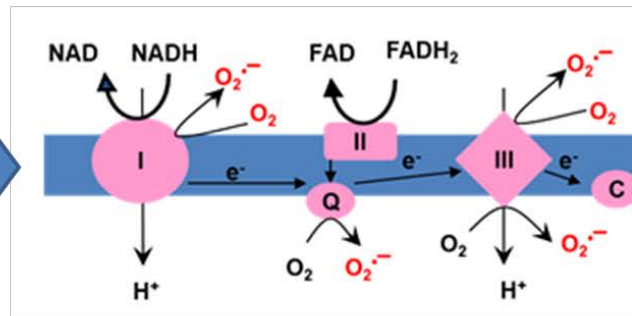

Reactive oxygen species (ROS)

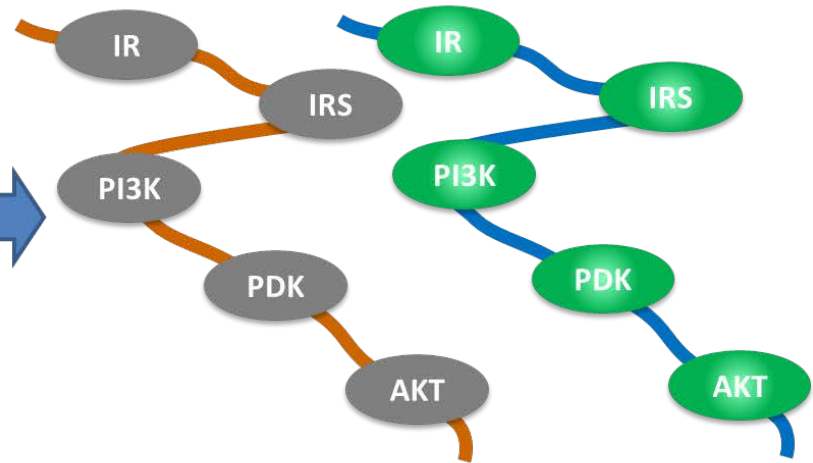

Compromised insulin signaling

Assessment (I)

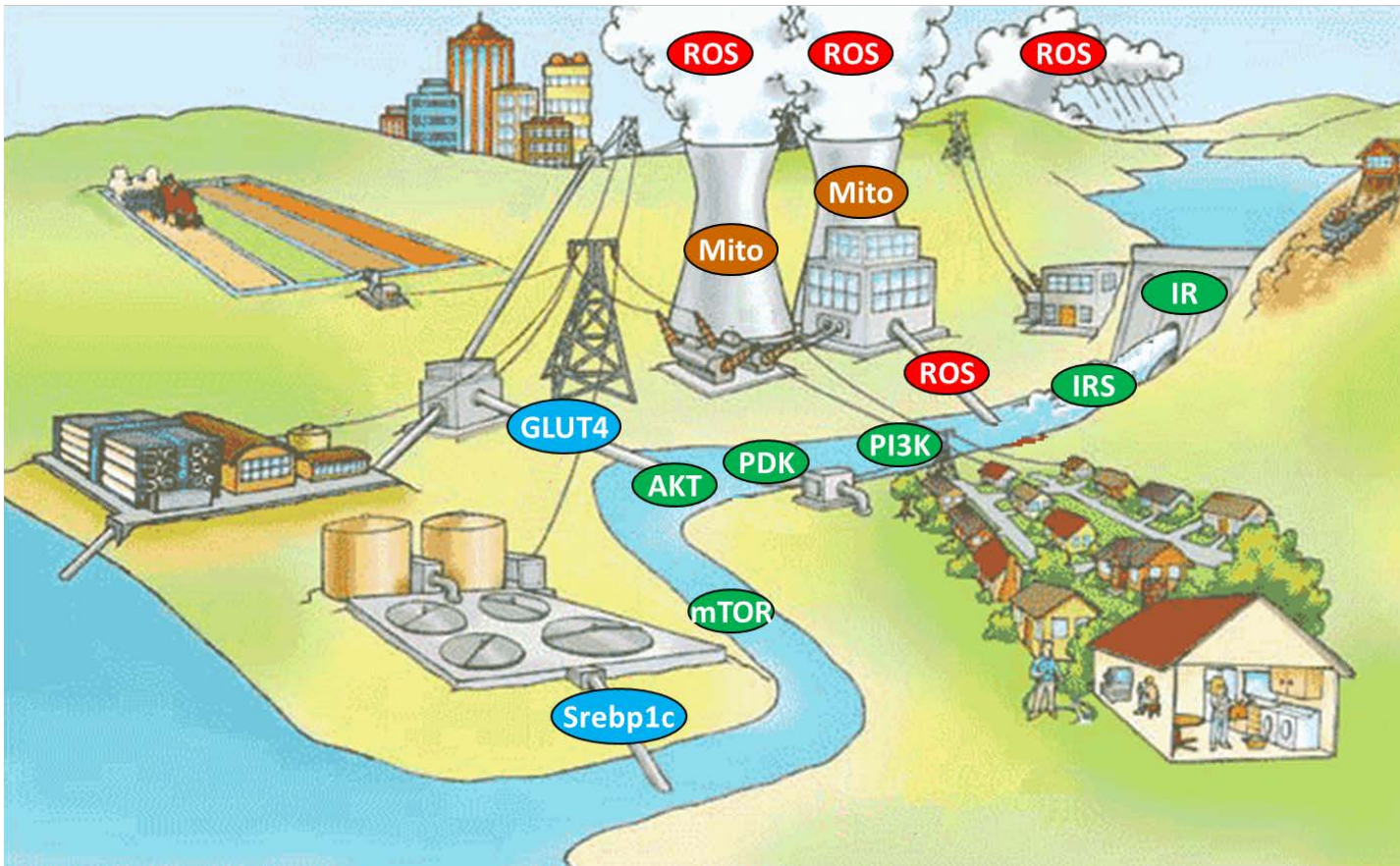

- ROS
- Mito
- IR
- Insulin signaling
- GLUT4
- Srebp1c

Assessment (II)

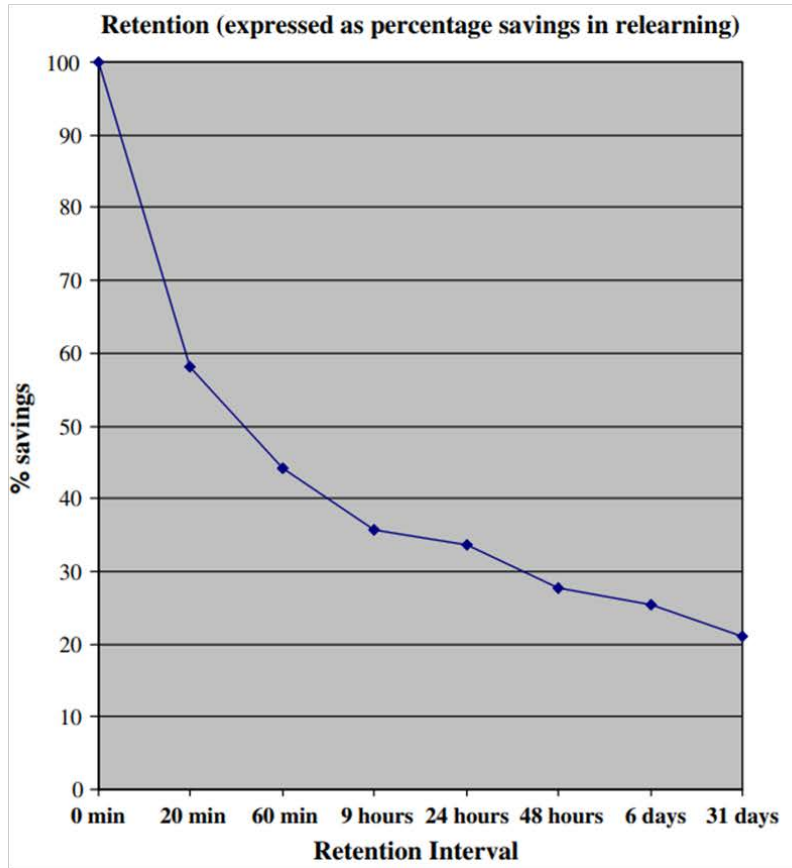

Custers EJFM (2010)

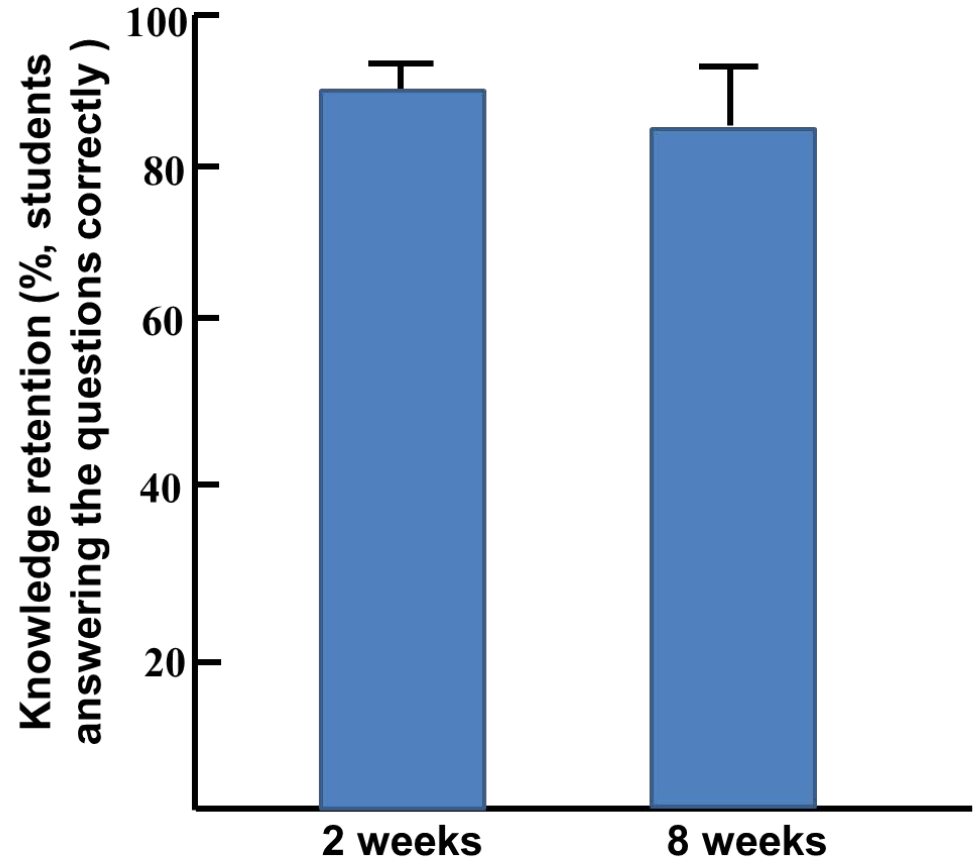

Assessment (III)

- His PowerPoint slides were very detailed and he gave a lot of analogies in lecture that were helpful for understanding the information. He is also very organized.
- Had interactive activities and practical scenarios. Let us try out drawing graphs first, and then reviewed them. Made class more applied, which I thought was helpful.
- Thank you so much for teaching Nutrition this semester! I really enjoyed it and learned a great deal. It was an extremely interesting class!

How to effectively use analogy

- To be effective, analogies must be familiar to students
- Analogies occurring in texts may be simple-based on surface similarities--or more complex, or based on similarities of function
- The features or functions of the base must be congruent with those of the target
- Sometimes multiple analogies must be used to teach the same concept
- Exercise caution to be sure that students remember the content, not just the analogy
- Analogies are not necessarily fully accurate but help the students understand the concepts
 - *“If you try to find perfect analogies for concepts in science, you will find very few”* (Seiler 2016)
- Acknowledging the differences between the base vs target (i.e., the limitation of a analogy)
 - The feature or relations that the base and target share and do not share
 - The analogy of (water, pipe) vs (blood, blood vessel)
 - Water and blood differ in their mechanical properties (water is a Newtonian fluid, whereas blood is not)
 - Elasticity is an important attribute of blood vessels but not necessarily of a pipe
 - The analogy of (engine, car) vs (mitochondria, cell)
 - Many mitochondria in a cell but only one engine in a car
 - Substrate transport and uptake in cells is complicated and varies with types of cell and nutrient, while filling cars with gas is much simpler.
- Having students create their own analogies

Summary

- Abstract or complex concepts are easier to understand via analogy, where they are related to and visualized by something from our everyday experiences.
- Analogy help familiarize students with concepts that are abstract and outside their previous experience
 - Facilitates explanation of complex concepts
 - Motivates students to learn
 - Helps construct students' knowledge
- A perfect analogy for a given target does not exist
 - An effective analogue focuses on the overarching concept
 - Acknowledging the limitation of an analogy (e.g., how the base differs from the target) to avoid confusion or misconceptions
 - Use of multiple analogies for the same concept may enhance the power explanation